

LEGS-LT03

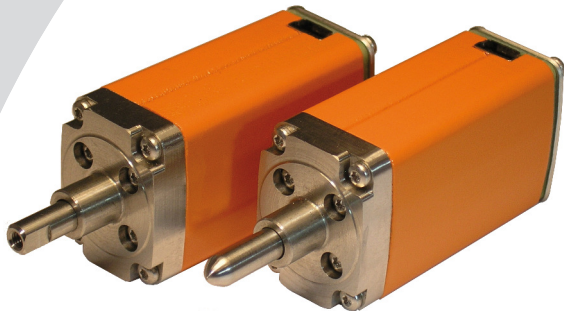

Ordering Information	
LEGS-LT03S-10	Threaded mounting
LEGS-LT03S-11	Clamp mount, shaft w thread
LEGS-LT03S-12	Clamp mount, shaft w round tip
Options	
LEGS-LT03-XX	Customized shaft
Accessories	
PMD90	Microstepping Driver
PMCM31-01	PiezoMotor Driver Model PDA 3.1
PMCM21-01	Handheld driver

Key Features

- Mirror Mount applications
- High resolution
- Very high speed dynamics
- Direct linear drive – no gears or lead screws
- No power in hold position
- Very simple drive electronics
- High force in a small package

The Piezo LEGS® 20N linear motor is intended for use in laser and optics applications moving mirror mounts etc. The very high speed dynamics of the motor makes it very fast and easy to setup.

The -20 version has a shaft with flat surfaces and a thread in the front for easy attachment in general applications.

The motor is ideally suited for move and hold applications or for automatic adjustments. This is due to the fact that the motor does not require any power in hold position as well as that the motor has no back-lash and can move in increments of single nanometers. The Piezo LEGS® linear motor is available in a number of different versions for example vacuum and non-magnetic environments (see separate data sheets).

Drive Technology

The motor is using the patented Piezo LEGS® technology.

Controlling the motor

The range of drivers include simple full step drivers (example: PDA3.1 from PiezoMotor) as well as more advanced micro-stepping drivers that can fully utilize the high performance of the Piezo LEGS® technology (example: PMD90). Other drivers are available from PiezoMotor as well as other independent companies (see piezomotor.com for details).



Simple electronics

For users wishing to fully integrate drivers into the overall electronic system PiezoMotor can supply all relevant information, like waveforms and movement patterns, to design such custom integrated drive systems. The motor is operating in a non-resonant mode and is not sensitive to different cable lengths etc.

Open Loop/Closed Loop Operation

The motor can be moved in full steps, shorter steps or partial steps (micro-stepping) giving positioning resolution in the nanometer range. For extreme positioning requirements in the sub-nanometer range a bending mode is possible. Speed is easily adjustable from extremely low up to max specified.

Notes

The mounting holes on the underside of the motor are not available in this version.

Additional information is available upon request, info@piezomotor.com

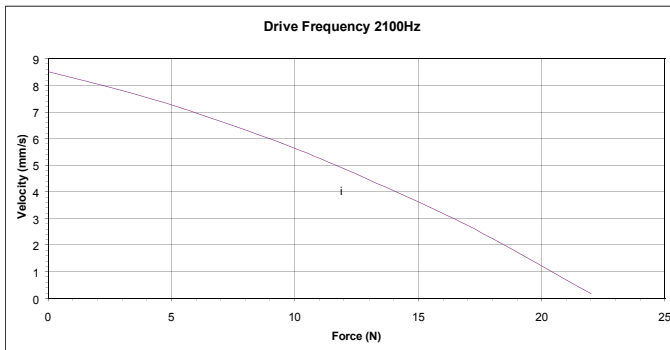

Velocity and Load

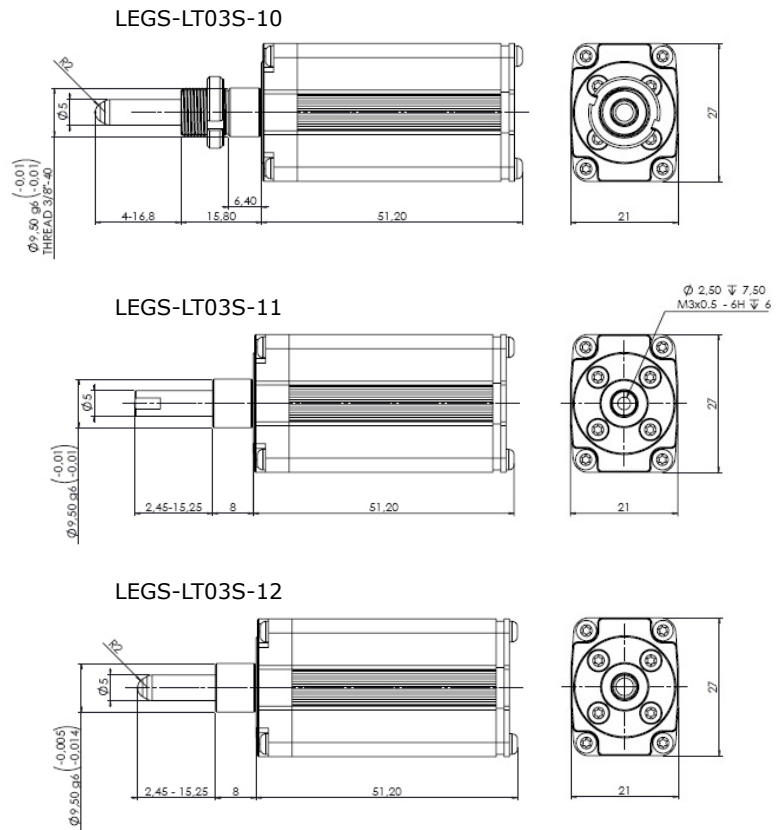

Mechanical Drawing

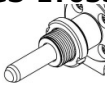

Technical Specification

Type				Unit	Note
Stroke max	12.8	12.8	12.8	mm	35 mm standard
Maximum Speed	15	15	15	mm/s	at no load
Resolution	<1	<1	<1	nm	Bending mode
Max Voltage	42	42	42	V	
Stall Force max	20	20	20	N	
Holding Force max	22	22	22	N	
Surface	alum. housing	alum. housing	alum. housing		
Material	stainless steel	stainless steel	stainless steel		
Connector	USB mini	USB mini	USB mini		
Mechanical Size	51.2 x 21 x 27	51.2 x 21 x 27	51.2 x 21 x 27	mm	See drawing for details
Weight	95	95	95	gr	
Operating Temp.	0 to +50	0 to +50	0 to +50	°C	

Note: All specifications are subject to change without notice



PiezoMotor Uppsala AB
 Stålgatan 14
 SE-754 50 Uppsala, Sweden

Telephone: +46 18 489 5000
 Fax: +46 18 489 5001

info@piezomotor.com
 www.piezomotor.com

LMA008-13027-01