

LEGS-L01NM-11



Key Features

- Non Magnetic Version
- High resolution
- Very high speed dynamics
- Direct linear drive – no gears or lead screws
- No power in hold position
- Very simple drive electronics
- High force in a small package

The Piezo LEGS® 10N linear motor is intended for a very large range of applications. The motor is ideally suited for move and hold applications or for automatic adjustments. This is due to the fact that the motor does not require any power in hold position as well as that the motor has no back-lash and can move in increments of single nanometers. The Piezo LEGS® linear motor is available in a number of different versions for example vacuum and non-magnetic environments (see separate data sheets). The maximum force of the motor is set by adjusting the number of springs giving the normal force. The motor is normally set for 6.5N (standard) or 10N (optional) which is the maximum force. The motor is easily integrated and the drive rod can also be equipped with a metal drive rail adapter (optional) to further facilitate the mechanical integration in many systems.

Drive Technology

The motor is using the patented Piezo LEGS® technology.

Controlling the motor

The range of drivers include simple full step drivers (example: PDA3.1 from PiezoMotor) as well as more advanced micro-stepping drivers that can fully utilize the high performance of the Piezo LEGS® technology (example: PMD90). Other drivers are available from PiezoMotor as well as other independent companies (see piezomotor.com for details).

Ordering Information

LEGS-L01NM-11	Standard Non Magnetic
---------------	-----------------------

OPTIONS

LEGS-L01NM-11S	Non-standard force, drive rod length, drive rod attachment, drive rod guidance, cable length, cable sleeve – specify at order
----------------	---

ACCESSORIES

PMD90	Microstepping Driver
PMCM31	PiezoMotor Driver Model PDA 3.1
10072	Adapter for drive rod



PMD90

Simple electronics

For users wishing to fully integrate drivers into the overall electronic system PiezoMotor can supply all relevant information, like waveforms and movement patterns, to design such custom integrated drive systems. The motor is operating in a non-resonant mode and is not sensitive to different cable lengths etc.

Open Loop/Closed Loop Operation

The motor can be moved in full steps, shorter steps or partial steps (micro-stepping) giving positioning resolution in the nanometer range. For extreme positioning requirements in the sub-nanometer range a bending mode is possible. Speed is easily adjustable from extremely low up to max specified.

Notes

The mounting holes on the underside of the motor are not available in this version.

Additional information is available upon request, info@piezomotor.com

Velocity and Load

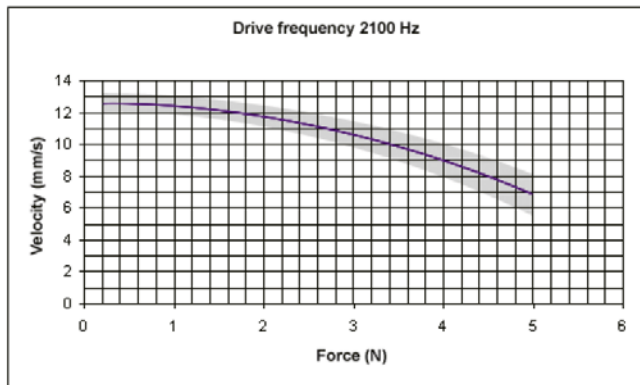

Note: Data above is for a max stall force of 6.5N.

Mechanical Drawing

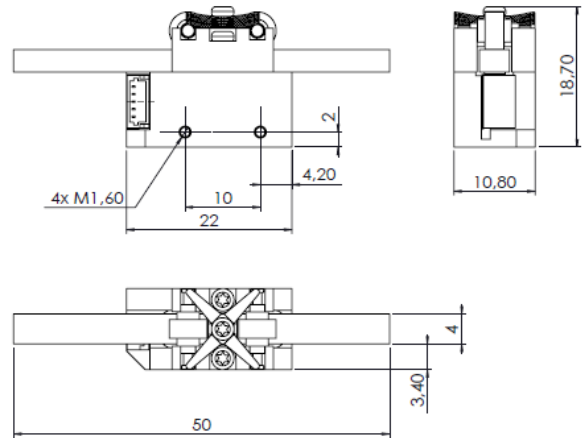

Connector Type and Pin Assignment

The motor connector is JST BM05B-SRSS-TB.

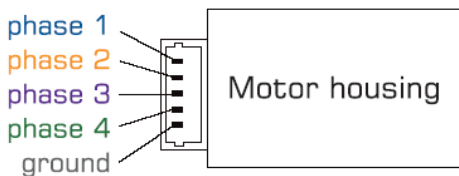

1 Ground is floating from chassis/protective GND (PGND).

Mounting the motor

The motor should be mounted with shims in between the motor housing and the attachment to make the installation insensitive to any uneven surfaces. The motor is a precision motor and mechanical distortion of the motor housing due to incorrect mounting can severely affect motor performance.

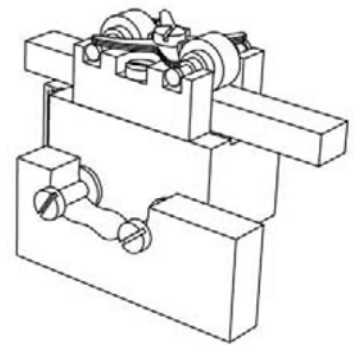

Technical Specification			
Type	LEGS-LO1NM-11	Unit	Note
Drawing No	LAB000-31001		
Stroke max	55	mm	35mm standard
Maximum Speed	20	mm/s	
Resolution	<1	nm	Bending mode
Max voltage	42	V	
Stall force max	10	N	Set by spring force
Holding force max	11	N	Set by spring force
Surface	bare metal		
Mechanical size	22x10.8x18.7	mm	See drawing for details
Weight	20	gram	
Operating Temp	-20 - +70	°C	
Encoder type	N/A		
Encoder resolution	N/A	nm	
Encoder interface	N/A		

Note: All specifications are subject to change without notice.