

THE INFORMATION CONTAINED IN THIS DRAWING IS THE SOLE PROPERTY OF Piezomotor Uppsala AB ANY REPRODUCTION IN PART OR WHOLE WITHOUT THE WRITTEN PERMISSION OF Piezomotor Uppsala AB IS PROHIBITED.

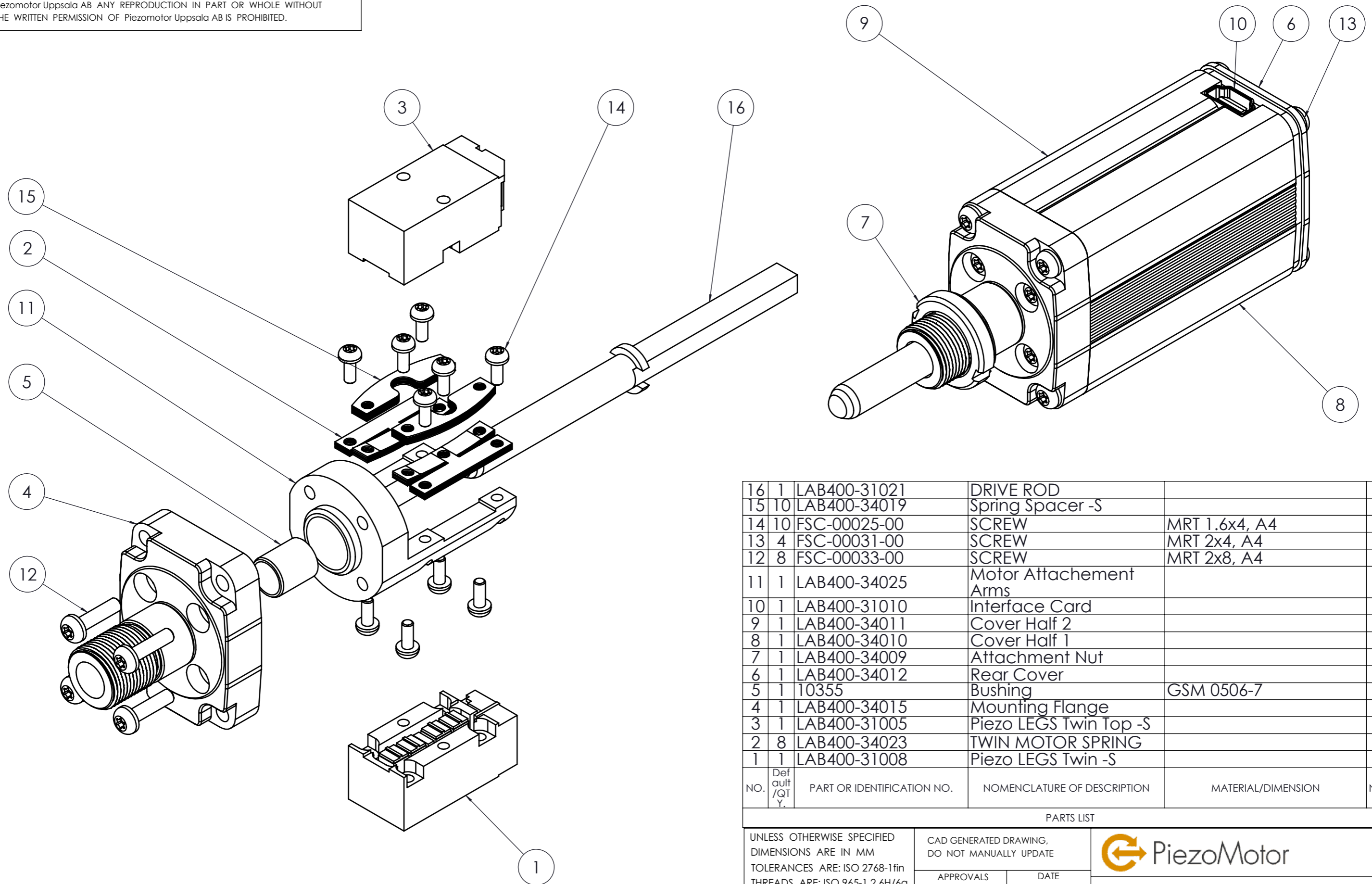

NO.	Def ault /QT Y.	PART OR IDENTIFICATION NO.	NOMENCLATURE OF DESCRIPTION	MATERIAL/DIMENSION	NOTE
16	1	LAB400-31021	DRIVE ROD		
15	10	LAB400-34019	Spring Spacer -S		
14	10	FSC-00025-00	SCREW	MRT 1.6x4, A4	
13	4	FSC-00031-00	SCREW	MRT 2x4, A4	
12	8	FSC-00033-00	SCREW	MRT 2x8, A4	
11	1	LAB400-34025	Motor Attachment Arms		
10	1	LAB400-31010	Interface Card		
9	1	LAB400-34011	Cover Half 2		
8	1	LAB400-34010	Cover Half 1		
7	1	LAB400-34009	Attachment Nut		
6	1	LAB400-34012	Rear Cover		
5	1	10355	Bushing	GSM 0506-7	
4	1	LAB400-34015	Mounting Flange		
3	1	LAB400-31005	Piezo LEGS Twin Top -S		
2	8	LAB400-34023	TWIN MOTOR SPRING		
1	1	LAB400-31008	Piezo LEGS Twin -S		

PARTS LIST

UNLESS OTHERWISE SPECIFIED
DIMENSIONS ARE IN MM
TOLERANCES ARE: ISO 2768-1fin
THREADS ARE: ISO 965-1,2 6H/6g
DIAMETER H12/h12 ANGLES ±1°

MATERIAL

FINISH

DO NOT SCALE DRAWING

CAD GENERATED DRAWING,
DO NOT MANUALLY UPDATE

APPROVALS		DATE
DRAWN	PBN	2009-05-07
REVISD		
REVIEWED	LHR	2009-05-07
APPROVED	ALN	2009-05-07
SCALE	2:1	



LEGS Linear TS Thread
Optical Mount version

SIZE	DWG. NO.	REV.
A3	LEGS-LT03S-10	00

THE INFORMATION CONTAINED IN THIS DRAWING IS THE SOLE PROPERTY OF Piezomotor Uppsala AB ANY REPRODUCTION IN PART OR WHOLE WITHOUT THE WRITTEN PERMISSION OF Piezomotor Uppsala AB IS PROHIBITED.

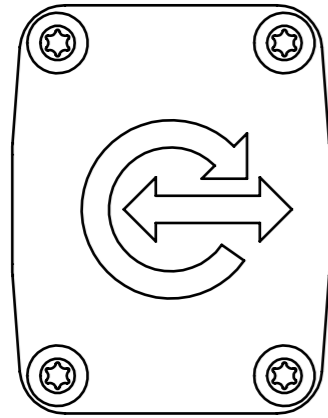

$\phi 9,50\ g6$
 $(-0,01)$
 $(-0,01)$
 THREAD 3/8"-40

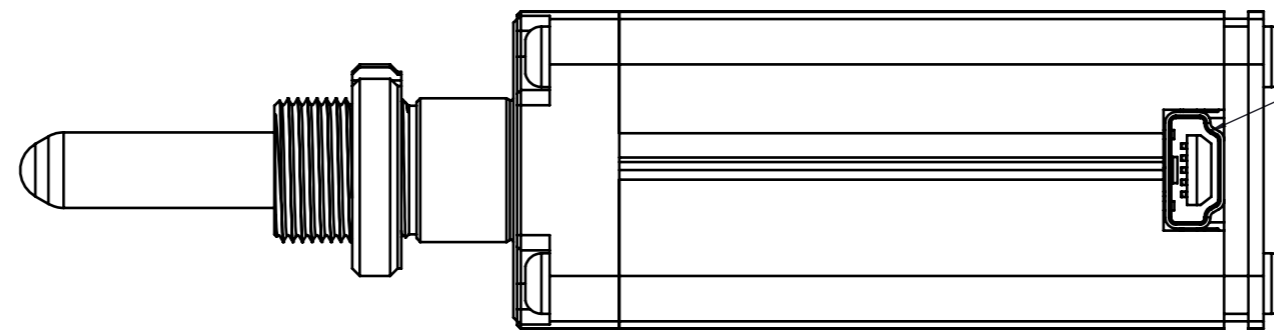
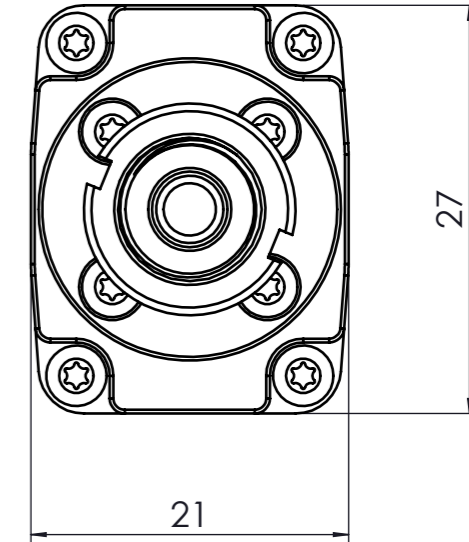
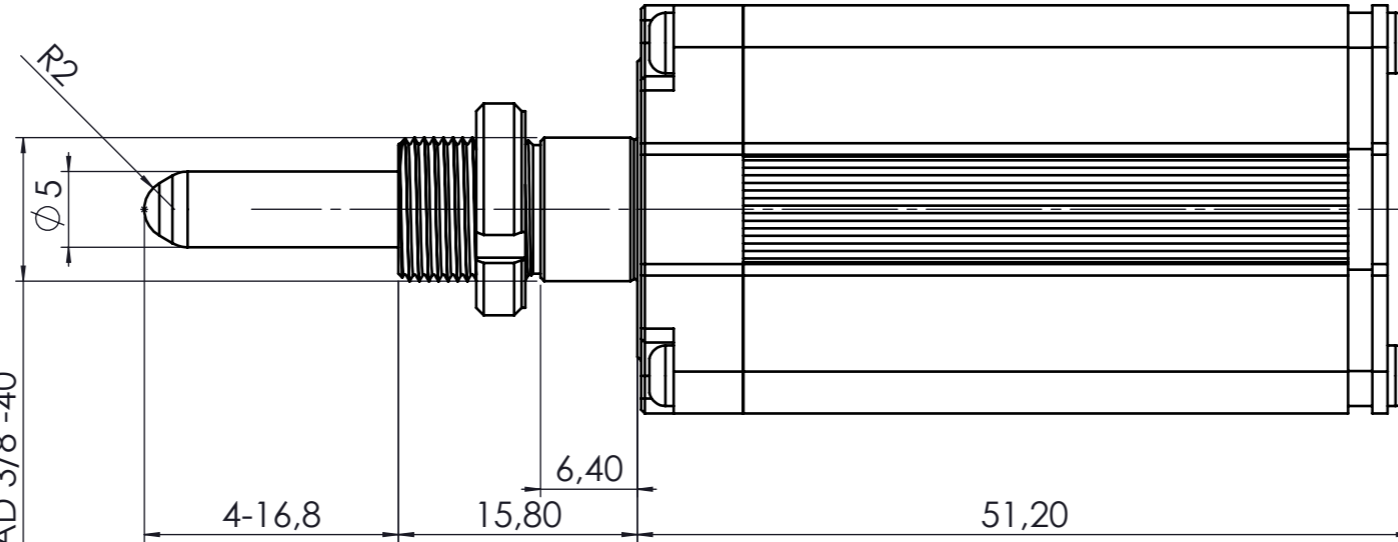

Connector: USB Mini typ B
5-pin

UNLESS OTHERWISE SPECIFIED
 DIMENSIONS ARE IN MM
 TOLERANCES ARE: ISO 2768-1fin
 THREADS ARE: ISO 965-1,2 6H/6g
 DIAMETER H12/h12 ANGLES $\pm 1^\circ$

MATERIAL

FINISH

DO NOT SCALE DRAWING

CAD GENERATED DRAWING,
DO NOT MANUALLY UPDATE

APPROVALS		DATE
DRAWN	PBN	2009-05-07
REVISED		
REVIEWED	LHR	2009-05-07
APPROVED	ALN	2009-05-07
SCALE	2:1	



LEGS Linear TS Thread
Optical Mount version

SIZE A3	DWG. NO. LEGS-LT03S-10	REV. 00
------------	---------------------------	------------

CAD FILE: LEGS-LT03S-10 LEGS Linear TS w Thread 01

SHEET 1 OF 1

